

AN ELECTRONIC GROUNDWATER-LEVEL DETECTOR WITH AUTOMATIC OUTPUT REGISTRATION

W.P. VAN RIJN¹) and K.J. WEBER¹)

ABSTRACT

A simple, robust, electronic groundwater-level detector has been constructed which measures the water level in piezometers with an accuracy of better than ± 1 mm. A series of these instruments can be connected to an automatic digital recording system. Measurements can be performed according to a selected programme of measuring times. The reference level at each level-detector location is indicated by gauging glasses attached to a system of interconnected liquid-filled tubes.

1. INTRODUCTION

In the course of pumping experiments to determine the permeability distribution in a holocene distributary channel-fill near Leerdam, the need was felt for an improved method of measuring the profile of the piezometric surface. The measuring of water levels in piezometers by hand with the aid of hollow-ended dippers attached to a measuring tape is both inaccurate and time consuming. It is of interest, particularly at the start of an experiment, to observe the movement of the water level around the pumping well with a frequency which is difficult to achieve with hand-operated piezometers, unless an observer is available at every piezometer location. Furthermore, piezometer measurements by hand reduce the possible duration of experiments to a normal working day, unless several shifts of observers are employed. A hand measurement is accurate to no more than a few millimetres, while the results are biased by differences

in aptitude of the various observers, and possible administrative errors.

To eliminate the above difficulties, a level detector has been constructed which measures the water level in a piezometer with the aid of an electrode suspended on a steel wire. The steel wire is wound on a drum, which is powered by an electric motor. The movement of the drum is registered by a potentiometer. The apparatus can be activated by remote control and the potentiometer readings can be collected centrally by a digital recorder. A timing device can be preset to provide piezometer readings in a given order, according to a selected programme of measuring times. The system is accurate to within about 1 mm, while the range of vertical movement of the electrode is 2 m in the existing apparatus.

The reference level at each piezometer station can be determined easily with the aid of a system of interconnected liquid-filled tubes which are provided with gauging glasses at each level detector. The potentiometers can be preset individually to any suitable value. This system of observing the relative height of the apparatus with respect to a chosen zero-level eliminates the time-consuming and very accurate levelling measurements that are otherwise necessary.

A set of twenty of these groundwater-level detectors has been made and is available for future hydrological experiments by KSEPL. The licence for commercial production of the apparatus is in the hands of NV Verenigde Instrumentenfabrieken ENRAF-NONIUS, Delft.

¹) Koninklijke/Shell Exploratie en Productie Laboratorium Rijswijk, The Netherlands.

2. WORKING PRINCIPLE

The components of the instrument are shown in figures 1 and 2. The platinum-tipped electrode is suspended by a flexible steel wire, which is wound on a drum. The electrode can be raised or lowered by means of a DC motor. The axis of the drum is connected to a potentiometer, which produces a signal proportional to the movement of the electrode.

The DC motor is switched on and off by an electronic circuit that reacts when the electrode makes contact with the water surface in the piezometer tube. When the downward-moving electrode touches the water, the electrode is stopped and starts moving upwards until contact with the water ceases, at which moment the movement is again reversed. Thus the electrode keeps following the water level until the instrument is switched off. The accuracy of the measurements is better than 1 mm.

The connection between wire-drum axis and the potentiometer can be unlocked, allowing adjustment of the potentiometer dial at any time. This makes it easy to set the potentiometer readings of all instruments at zero at the start of a test, with all electrodes

at exactly the same reference level. The relative height of each level detector can be determined very quickly with the aid of a system of interconnected tubes which run to all piezometer locations, and are provided with a gauging glass at each location (see fig. 3). This simple levelling system is very accurate and eliminates the need for time-consuming levelling measurements by a surveyor.

3. CONSTRUCTION

In the construction of the apparatus, the aim has been to produce a simple, strong configuration, suitable for use under adverse weather conditions. Furthermore, the apparatus had to be light, and installation and servicing had to be quick and easy.

The workings and electronic circuit have been mounted on an aluminium base plate (see fig. 1). The instrument is enclosed by a water-tight case made from hard plastic (see fig. 2). The switch for manual operation and the potentiometer dial are located behind a sliding panel. The apparatus is supported by three legs.

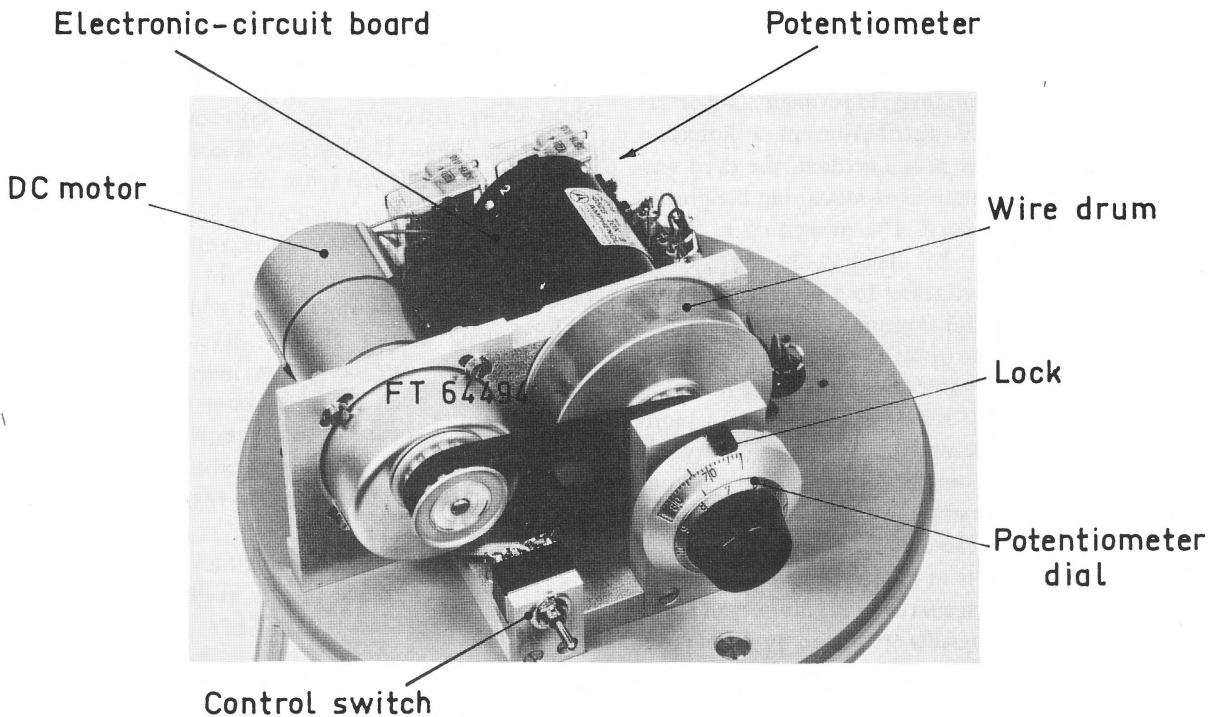

Fig. 1
Workings of the instrument.

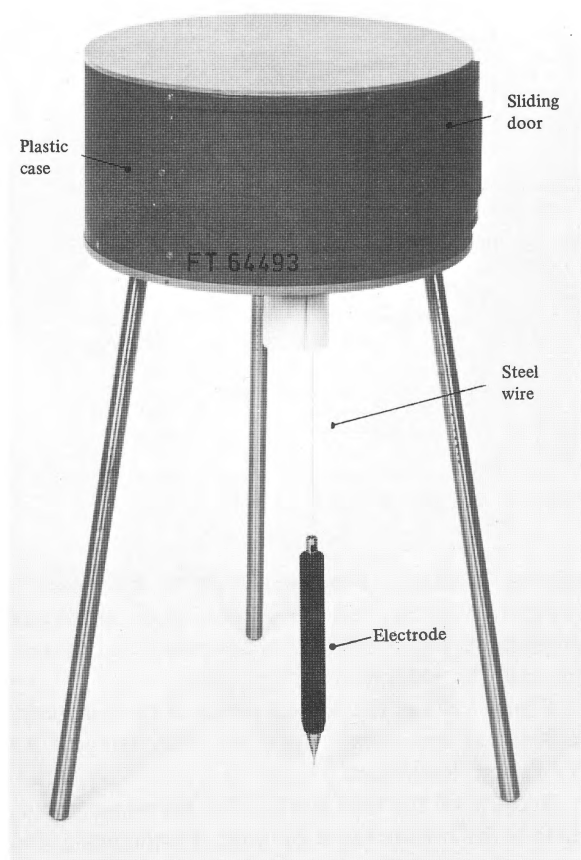

Fig. 2
Level detector.

The electrode is about 12 mm in diameter, to enable it to operate in narrow piezometer tubes. The tip of the electrode is specially shaped to minimise the surface-tension effects when contact is made with the water level. In this way, a measuring accuracy of better than ± 1 mm has been achieved. The length of the steel wire is such that the electrode can move over a vertical range of 2 m. This range can easily be changed by installing another wire drum.

The cable transmitting the current supply (12V, D.C.) and the output signals is plugged into the underside of the base plate (see fig. 3).

The gauging glass of the levelling system can be attached to the side of the apparatus. When installing a level detector in the field, a geological compass is required to ensure that the instrument is in a horizontal position. Alternatively, one can attach a spirit level to the top of the apparatus.

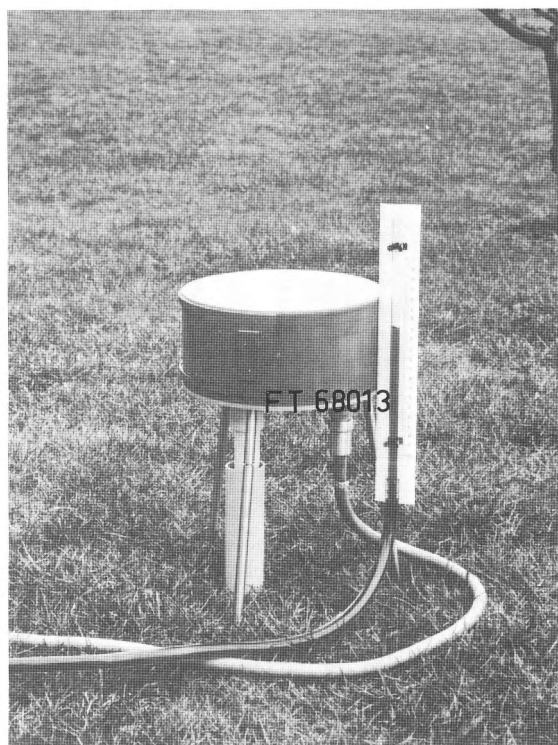

Fig. 3
Level detector in operation in the field.

4. REMOTE CONTROL AND AUTOMATIC REGISTRATION

The most accurate method of performing a series of measurements according to predetermined time schedules is to make use of a digital recording system provided with an automatic scanner. In figure 4 the various components of the system that we have adopted are shown in a block diagram.

The level detectors are connected in groups of 10 to junction boxes, which in turn are connected to a power supply and the relay box of a scanner.

At the start of a measuring cycle, the power supply (12V DC) for all level detectors is switched on automatically by a programmer for a period of 10 seconds. Thus all electrodes adjust themselves to the water level at that time. Also, the digital clock is connected to the printer via a converter, so that the period of each measuring cycle can be registered in hours and minutes. A special programmer can provide the facility to command the scanner to carry out a series of measuring cycles according to a given programme.

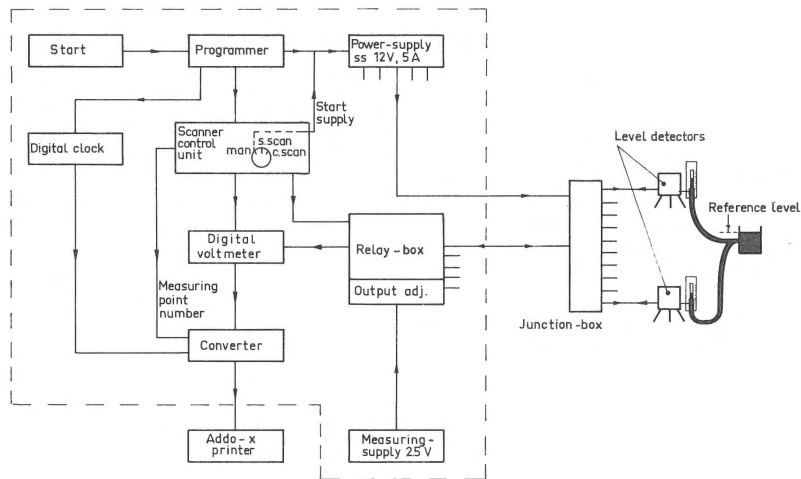

Fig. 4
Block diagram of automatic digital recording system.

The maximum speed of the scanner is limited by the performance of the printer to one measurement per second. The maximum number of level detectors than can be handled by the scanner is 50. The signals are measured with a digital voltmeter, the printout of which is connected via the convertor to an Addo-X printer. The level-detector number is printed out together with the time and the level reading.

The scanner switch has three positions: manual operation, programmed automatic scanning or con-

tinuous scanning. For each type of hydrological experiment there will be an optimum measuring programme for which the above-mentioned system can easily be adapted.

Figure 5 shows the control panels of the automatic registration apparatus, which was manufactured by NV Peekel, Rotterdam.

Because of the high level of the signals measured, there is little disturbance by noise. Furthermore, one can compensate for the cable resistance, making it

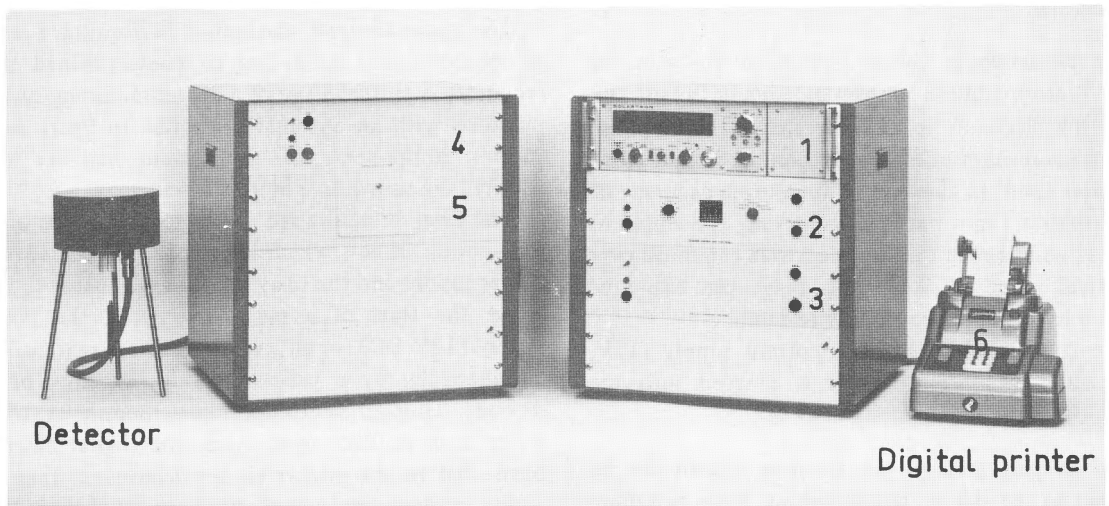

1. Digital voltmeter. 2. Scanner control unit. 3. Printout converter. 4. Digital clock-programmer-power/measurement supply. 5. Relay box – output adjustment. 6. Addo-X printer.

Fig. 5
Automatic registration apparatus

possible to measure the water level in piezometers to a high degree of accuracy several kilometres from the registration unit. The registration unit allows a hydrological experiment to be undertaken by two or three operators, once the pumping wells) and piezometers have been installed.

5. CONCLUSIONS

The electronic groundwater-level detector is a

simple but accurate tool for use in experiments involving piezometers. The cost of the instruments is quickly offset when a series of experiments is performed, because of the reduction in manpower requirements. The automatic registration unit simplifies the administration and improves the reliability of level and time readings. Furthermore, the measurements can be carried out according to tight, complicated time schedules, which would prove difficult by hand.